

ELECTRIC SCISSOR LIFTS

COMPACT 8 W COMPACT 10 / 12

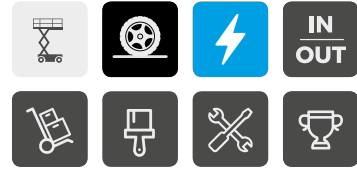

EXCEPTIONAL PRODUCTIVITY

- > Load capacity up to 450 kg (C 8 W and C 10)
- > Driveable at full height
- > Both inside and outside use with the same load capacity
- > Extended platform
- > Width of 1.2 m

ROBUST, RELIABLE, EASY TO MAINTAIN

- > Long working cycles

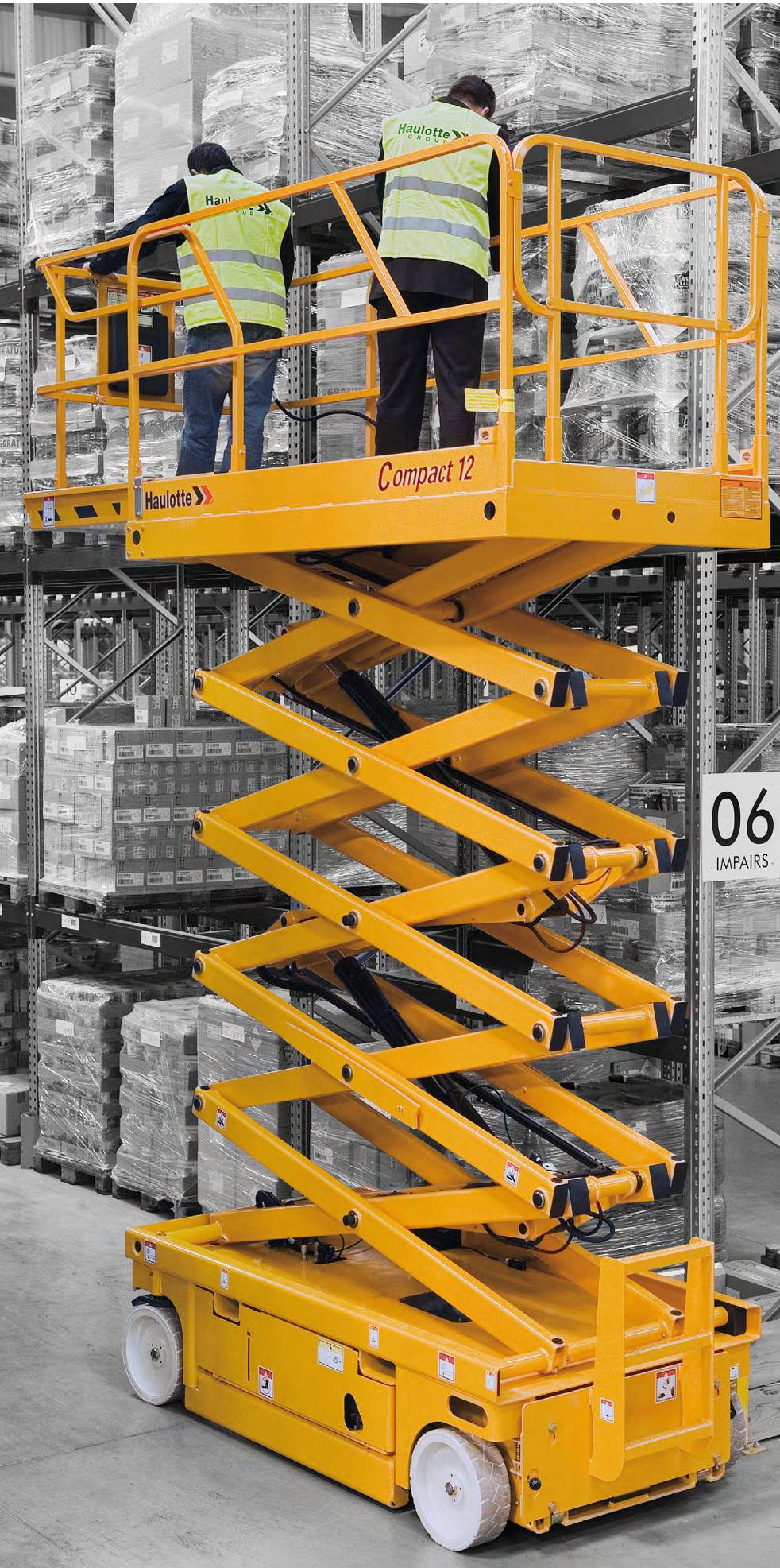

COMPACT 8 W COMPACT 10 / 12

ELECTRIC SCISSOR LIFTS

TECHNICAL DATA

	COMPACT 8 W	COMPACT 10	COMPACT 12
Working height	8.27 m	10.15 m	11.98 m
Platform height	6.27 m	8.15 m	9.98 m
Maximum drive height	6.27 m	8.15 m	9.98 m
Lift capacity - inside	450 kg (3 pers.)	450 kg (2 pers.)	300 kg (2 pers.)
Lift capacity - outside	450 kg (3 pers.)	450 kg (1 pers.)	300 kg (1 pers.)
Lift capacity on the extension	150 kg	150 kg	150 kg
A Platform length - outside	2.31 m	2.31 m	2.31 m
B Platform length - extended	3.23 m	3.23 m	3.23 m
Length - extension	0.92 m	0.92 m	0.92 m
C Platform width - outside	1.2 m	1.2 m	1.2 m
E Storage height	1.28 m	1.4 m	1.53 m
D Height - stowed	2.14 m	2.26 m	2.39 m
F Overall width	1.2 m	1.2 m	1.2 m
G Length	2.49 m	2.49 m	2.49 m
H Wheelbase	1.86 m	1.86 m	1.86 m
I Ground clearance - center	13 cm	13 cm	13 cm
Ground clearance - deployed potholes	2.5 cm	2.5 cm	2.5 cm
Drive speed	0.8 - 3.2 km/h	0.8 - 2.9 km/h	0.8 - 2.9 km/h
Gradeability	23 %	23 %	23 %
Tilt	3 °	2 °	2 °
Turning radius - outside	2.5 m	2.5 m	2.5 m
Non-marking tyres	15 x 5	15 x 5	15 x 5
Batteries	24 V - 340 Ah	24 V - 340 Ah	24 V - 340 Ah (C 20)
Hydraulic system capacity	25 l	25 l	27 l
Weight	2 030 kg	2 330 kg	2 470 kg

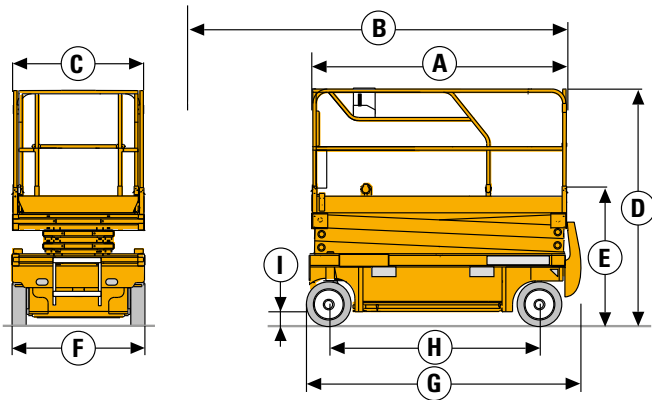

STANDARD EQUIPMENT

- > 2 front steering & driving wheels
- > Solid non-marking tyres
- > Free wheeling device
- > Removable control box in platform
- > Proportional lift and drive
- > Load Management System in the platform
- > Tilt controller
- > Swing out component tray
- > Horn
- > Hourmeter
- > 24 V DC motor
- > Battery charger with automatic stop
- > Battery charge indicator
- > Manual platform lowering valve
- > Towing hooks
- > Pothole guards
- > Integrated forklift pockets

OPTIONS AND ACCESSORIES

- > Power to platform
- > Biodegradable hydraulic oil
- > Traction batteries
- > Maintenance-free batteries
- > Centralised battery filling
- > Travel alarm
- > Flashing light
- > Working light
- > Folding guardrails

